

Rackmount Intelligent Pressure Scanners



NetScanner™ System

9816/98RK-1

FEATURES

- $\pm 0.05\%$ Accuracy
- 100 Hz EU Throughput
- Autonegotiating 10/100/1G Base T Ethernet - TCP and UDP Protocol
- Pressure Ranges up to 850 psid (5860 kPa)
- Rezero, Purge and Leak Check Functionality
- Triple Scan List Capability
- Hardware and Software Initiated Data Acquisition

APPLICATIONS

- Turbine Engine Research
- Turbomachinery Test Stands



Pressure Systems rackmount version of its highly successful NetScanner System features the latest generation Model 98RK-1 Scanner Interface Rack and Model 9816 Rackmount Intelligent Pressure Scanners for ultra high speed scanning of multiple pneumatic measurements in turbomachinery testing.

The enhanced Model 98RK-1 rack utilizes a high performance switch enabling the 9816 scanners to communicate with the host computer via an auto-negotiating 10/100/1G Base T Ethernet interface. The rack also provides power and pneumatic connections for up to eight internally-housed 9816 scanners. Additionally, the 98RK-1 can provide power and communication for up to three external NetScanner System components such as PSI's Model 9022 for all-media pressure measurements or Model 9032 for high-accuracy barometric or reference pressure measurements.

Model 9816 scanners integrate 16 silicon piezoresistive pressure sensors of any pressure range with a microprocessor. Each field-replaceable pressure sensor incorporates a temperature sensor and an integral EEPROM for storage of personalized calibration data as well as sensor information such as serial number, pressure range, factory calibration date, and user-managed last or next calibration date. Integrating the EEPROM within the sensor enables simplified field replacement of sensors with automatic uploading of sensor data during power up.

The microprocessor uses the sensor data to correct for zero, span, linearity and thermal errors. It also performs digital temperature compensation to reduce sensor thermal errors by a factor of ten or more over conventional compensation. The microprocessor also controls the actuation of an integral manifold to execute on-line zero calibrations upon request. This capability virtually eliminates sensor zero drift error and provides guaranteed system accuracy of up to $\pm 0.05\%$ FS (Full Scale) after rezero.

Each 9816 can sample using up to three concurrent scan lists at continuous rates up to 100 measurements per channel per second in engineering units. Pressure data is output over the Ethernet interface supporting both TCP and UDP protocols. The rack is supplied with comprehensive Visual Basic-based software called NUSS for PC compatible computers. Firmware upgrades are made available at no charge via our website and can be downloaded to the 9816 scanners using NUSS.

The NetScanner System is an array of system components measuring a variety of parameters and sharing the same command set that can be networked to form a comprehensive distributed intelligent data acquisition system.

34 Research Drive
Hampton, VA 23666
USA

www.PressureSystems.com

ISO-9001:2000 Certified

Phone: 757-865-1243
Toll Free: 800-328-3665
Fax: 757-865-8744
E-mail: sales@PressureSystems.com

© Copyright Pressure Systems, Inc., 2009

After 1 hour warmup @ 25°C with atmospheric reference pressure unless otherwise stated / FS = Full Scale

Parameter	9816	98RK-1	Units	Comments	
PNEUMATICS					
Pressure Ranges¹	10 (2.5) 20 (5.0)	N/A	in WC (kPa)	ranges < 100 psi (689 kPa) are bidirectional ranges ≥ 100 psi (689 kPa) are unidirectional	
	1 (7) 2.5 (17) 5 (34) 10 (69) 15 (103) 30 (207) 45 (310) 100 (689) 250 (1724) 500 (3447) 750 (5171) 850 (5860)	N/A	psid (kPa)		
Number of Measurement Inputs	16	N/A			
Pneumatic Fittings	0.063 bulged tubulation or SAE 5/16-24 o-ring boss (if front access specified)	SAE 7/16-24 o-ring boss			variety of compression adapter fittings available See page 6 for standard fittings
Media	Dry, non-corrosive gas				for liquid pressures refer to Model 9022 datasheet
Proof Pressure²	3.0X 2.0X 1.5X	NA	FS min		range < 15 psi (103 kPa) range 15-100 psi (103-689 kPa) range > 100 psi (689 kPa)
Burst Pressure	5.0X 3.0X 2.0X	N/A	FS min		range < 15 psi (103 kPa) range 15-100 psi (103-689 kPa) range > 100 psi (689 kPa)
Max Line Pressure³	100 (689) 600 (4134)	N/A	psi (kPa)		range ≤ 5 psi (34 kPa) range > 5 psi (34 kPa)
Manifold Control Pressure	80 (552) 125 (862)		psi (kPa)		min max
Purge Pressure⁴	> max input pressure 850 (5860)		psi (kPa)		min max
STATIC PERFORMANCE					
Measurement Resolution	±0.003	N/A	% FS		
Static Accuracy⁵ After Rezero	±0.05 ±0.15	N/A	% FS	range > 2.5 psi (17 kPa) range ≤ 2.5 psi (17 kPa)	
Total Thermal Error⁶	±0.001 ±0.0015	N/A	% FS/°C % FS/°C	range > 2.5 psi (17 kPa) range ≤ 2.5 psi (17 kPa)	
Line Pressure Effect	±0.0003	N/A	% FS/psi	range ≤ 100 psi (689 kPa)	
	±0.0008		% FS/psi	range > 5 psi (34 kPa) to < 100 psi (689 kPa)	
	±0.001		% FS/psi	range ≤ 5 psi (34 kPa)	
Measurement Rate	100	N/A	meas/ch/ sec	engineering units	

After 1 hour warmup @ 25°C with atmospheric reference pressure unless otherwise stated / FS = Full Scale

Parameter	9816	98RK-1	Units	Comments
COMMUNICATION				
Ethernet	10Base T half duplex	10/100/1000 Base T Auto negotiating		
Protocol	TCP and UDP		% FS	static or dynamic IP assignment
ELECTRICAL				
Input Voltage	N/A	85 - 264	VAC	47 – 63 Hz
Operating Power	N/A	65 ⁷	watts	
Hardware Trigger	2.5		VDC	TTL compatible differential input, ±5 VDC common mode voltage
ENVIRONMENTAL/PHYSICAL				
Compensated Temp Range	0 to 60		°C	
Operating Temp Range	0 to 50		°C	Up to 95% non-condensing humidity
Storage Temp	-20 to 80		°C	
Size	2.06 x 7.00 x 15.25 (5.2 x 17.7 x 38.7)	17.00 X 8.75 X 19.00 (43.2 X 22.2 X 48.3)	inches (cm)	L x W x H
Weight	6.5 (3.0)	26.9 (12.2)	lb (kg)	

Notes:

- 1 Consult Factory for intermediate pressure ranges and multirange configurations.
- 2 Maximum applied pressure without reducing sensor performance
- 3 For anticipated Line (Reference) Pressures . . .
 - above 100 psi (689 kPa) on FS pressure ranges of ≤ 5 psi (34 kPa) or
 - above 600 psi (4137 kPa) on FS pressure ranges of > 5 psi (34 kPa)
 - calibration manifold should not be shifted at line pressure
 - rate of line pressure change should be no more than 10 psi/sec
- 4 Purge pressure must be greater than maximum input pressure.
- 5 Static accuracy includes the combined errors due to non-linearity, hysteresis and non-repeatability.
- 6 Includes thermal effects of zero & span relative to 25°C.
- 7 Maximum power consumption with full compliment of 9816 scanners and remotely connected NetScanner modules in highest power draw configurations.

Specification subject to change without notice.

The Model 9816 Rackmount Intelligent Pressure Scanner combines integral pressure transducers with a miniature data acquisition system to provide a multichannel pressure scanner. The integration of the microprocessor with the pressure transducers provides several benefits in addition to the self-contained nature of the Intelligent Pressure Scanner. (This pre-engineered approach to pressure acquisition offers guaranteed system accuracy, unlike individual pressure transducers where stated accuracy is met only if the many user-considerations are addressed, especially with respect to temperature effects and zero drift.) The 9816 outputs pressure data in engineering units, digitally compensated for zero, span, nonlinearity and temperature effects. The integral pneumatic manifold permits on-line rezero and even span calibration capability under microprocessor control

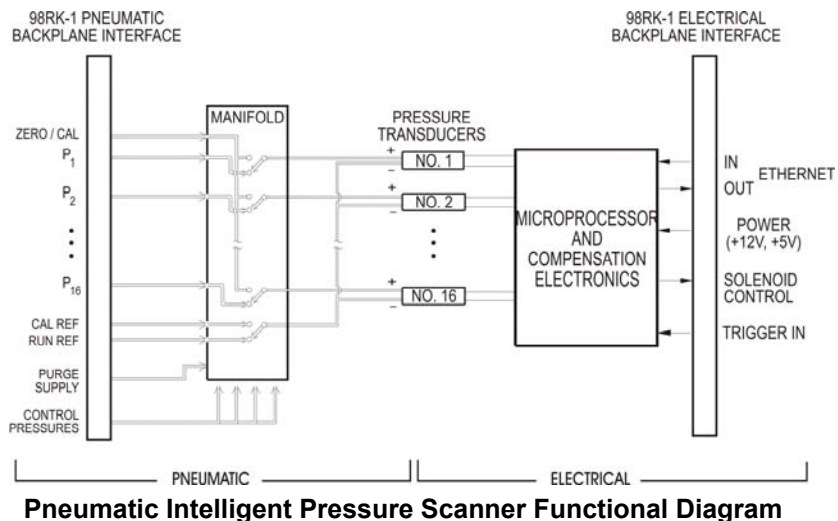

Pneumatic Intelligent Pressure Scanner Functional Diagram

Digital Sensor Temperature Compensation

Silicon piezoresistive pressure sensors are low cost, miniature pressure sensing elements ideal for packaging individually for each pressure port. However, like most sensors, they are affected by temperature. Since these effects are repeatable, sensor calibration over temperature and pressure can be used to characterize and correct these errors.

Each silicon pressure sensor is packaged along with a nonvolatile memory device (EEPROM) and a temperature sensor in its own miniature field-replaceable housing. The transducers are factory-calibrated over the specified pressure and temperature spans. The resultant calibration data, along with the pressure range and serial number of the sensor, are stored in the integral EEPROM. The microprocessor utilizes this information to compensate transducer outputs for offset, sensitivity, nonlinearity, and thermal effects before transferring pressure data to the host computer. Should a transducer be replaced, the microprocessor will recognize the new transducer upon power up and extract the calibration information from the EEPROM.

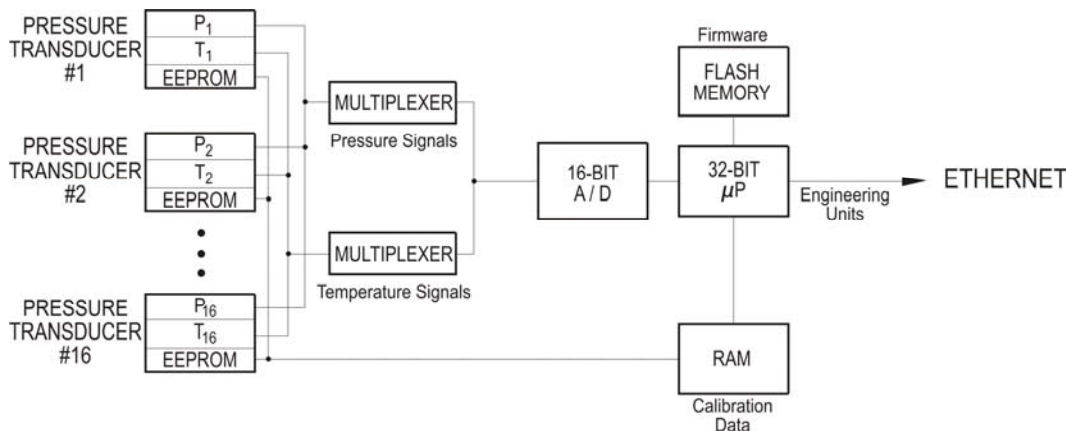

Digital Sensor Temperature Compensation Functional Diagram

Pneumatic Design

Model 9816 Rackmount Intelligent Pressure Scanners incorporate a unique manifold enabling on-line pneumatic rezero and span calibrations to maximize transducer accuracy. The manifold can be specified with either a common pressure reference or an individual pressure reference (true differential) per channel. Both configurations feature built-in purge and leak check capability of the pneumatic input lines as standard. The manifold utilizes a proprietary "O" ring seal providing years of leak free operation. If required, "O" rings can be replaced in the field using common tools.

Figures 1-4 illustrate the pneumatic function of the manifold for a single channel. Figures 1-3 depict the three manifold positions (RUN, CAL and PURGE). Figure 4 illustrates the LEAK CHARGE position for charging the input lines to execute a leak check.

To initiate these operations, the user simply issues the appropriate command via the host computer. Operating under control of the onboard microprocessor, integral solenoids are energized to apply control pressure to two of four pistons within the manifold. One piston forces the manifold longitudinally into the CAL position; another returns it to the RUN position. The remaining two pistons force the manifold laterally into either the PURGE or the LEAK CHARGE positions. Pressure of 80-125 psig (560 to 860 kPa) must be present at the Control Pressure Supply Input port on the rear of the 98RK-1 rack when the command is issued.

Rezero or span calibration functions place the manifold in the CAL position. Once there, data is acquired to update zero and/or span terms and the manifold is then returned to the RUN position. Span calibrations require the appropriate full scale pressure to be present at the respective calibration input ports on the rear of the rack.

The purge function requires pressure in excess of the highest anticipated input pressure to be present at the Purge Input port on the rear of the rack. Issuing the Purge command places the manifold into the PURGE position allowing purge pressure to exit the scanner through the input lines. Purging can require 1-3 scfm (75 lpm) of flow depending on applied purge pressure.

NOTE: On-line rezero or purge is not required to operate the scanner but ensures maximum accuracy.

The leak check function requires the desired test pressure to be applied to the appropriate calibration port on the rear of the rack and the input lines to be dead-ended at their source. Issuing the LEAK CHARGE command forces the manifold into the LEAK CHARGE position to charge the input lines using pressure from the respective calibration ports. Once charged, the manifold is commanded to the RUN position where periodic readings from the transducers can be obtained to analyze pressure decay in each input line.

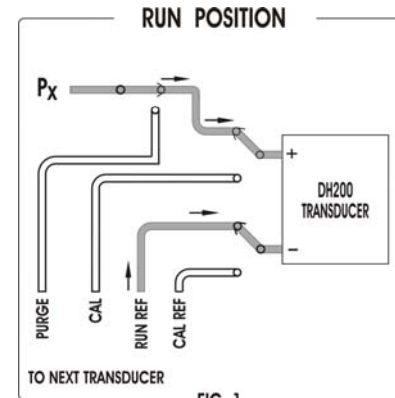

FIG. 1

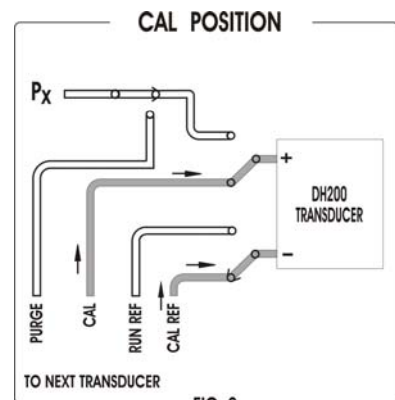

FIG. 2

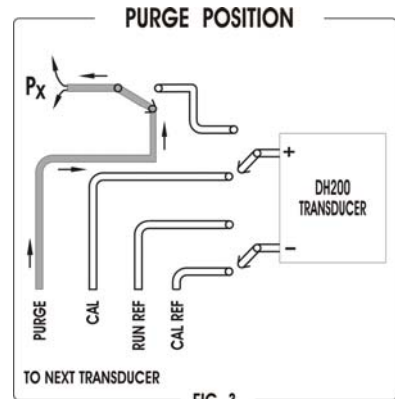

FIG. 3

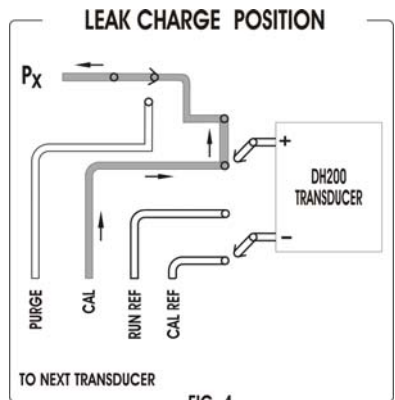
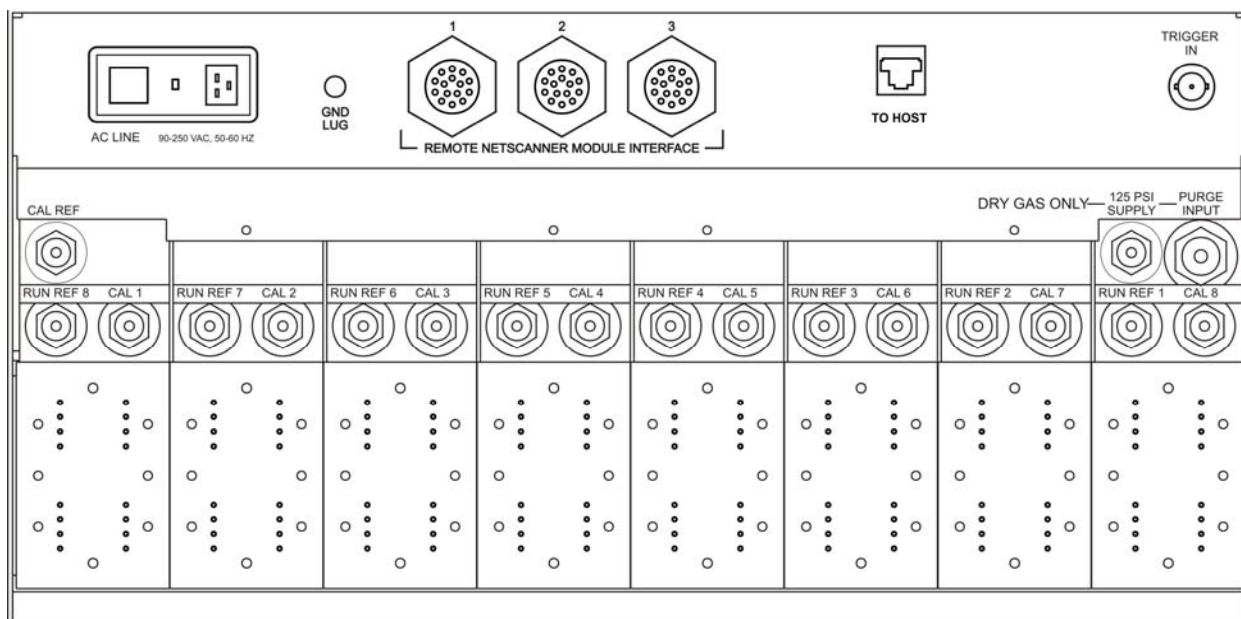

FIG. 4

The enhanced Model 98RK-1 Scanner Interface Rack is a 19" rackmountable chassis housing up to eight 9816 scanners. Electrical connections and utility pressures to service the scanners are made via the rear of the chassis. These connections are automatically made to the 9816 scanners once they are inserted into the chassis and secured with the integral locking rod. The 98RK-1 also provides Ethernet connection, hardware trigger and power supply for up to three remote Intelligent Pressure Scanners.

The 98RK-1 accepts a universal 85-264 volt 47-63 Hz power input. Measurement pressures can be input via the front of the scanners or the rear of the chassis. The scanners are keyed to receive span calibration pressures from one of eight calibration ports on the rear of chassis based on the range of their internal transducers. This eliminates the possibility of accidental overpressure while interchanging scanners within the chassis. These calibration ports also serve to provide leak check and accuracy verification pressures to the scanners. Pressure Systems manufactures a line of programmable pressure controllers to support these operations.

Both the 98RK-1 and the 9816 scanners incorporate front panel LED's to indicate the status of Ethernet links, power supply, scanner manifold position and system health.



98RK-1 Scanner Interface Rack Rear Panel Layout

STANDARD PNEUMATIC CONNECTIONS

	9816	98RK-1
Measurement Inputs	1/8" compression fitting or 0.063" OD bulged tubulation (if front access specified)	0.063" OD bulged tubulation (if rear access specified)
125 psi SUPPLY, CAL REF, RUN REF and CAL inputs (except CAL7 & CAL8)	N/A	1/4" compression fitting
CAL7 & CAL8	N/A	1/8" compression fitting
PURGE input	N/A	3/8" compression fitting

The NetScanner System allows for a combination of rackmount and stand-alone components to be networked. The illustration on this page shows a configuration for interfacing two 98RK-1 Scanner Interface Racks and three remote NetScanner components to a host computer. Contact PSI to discuss alternate network solutions.

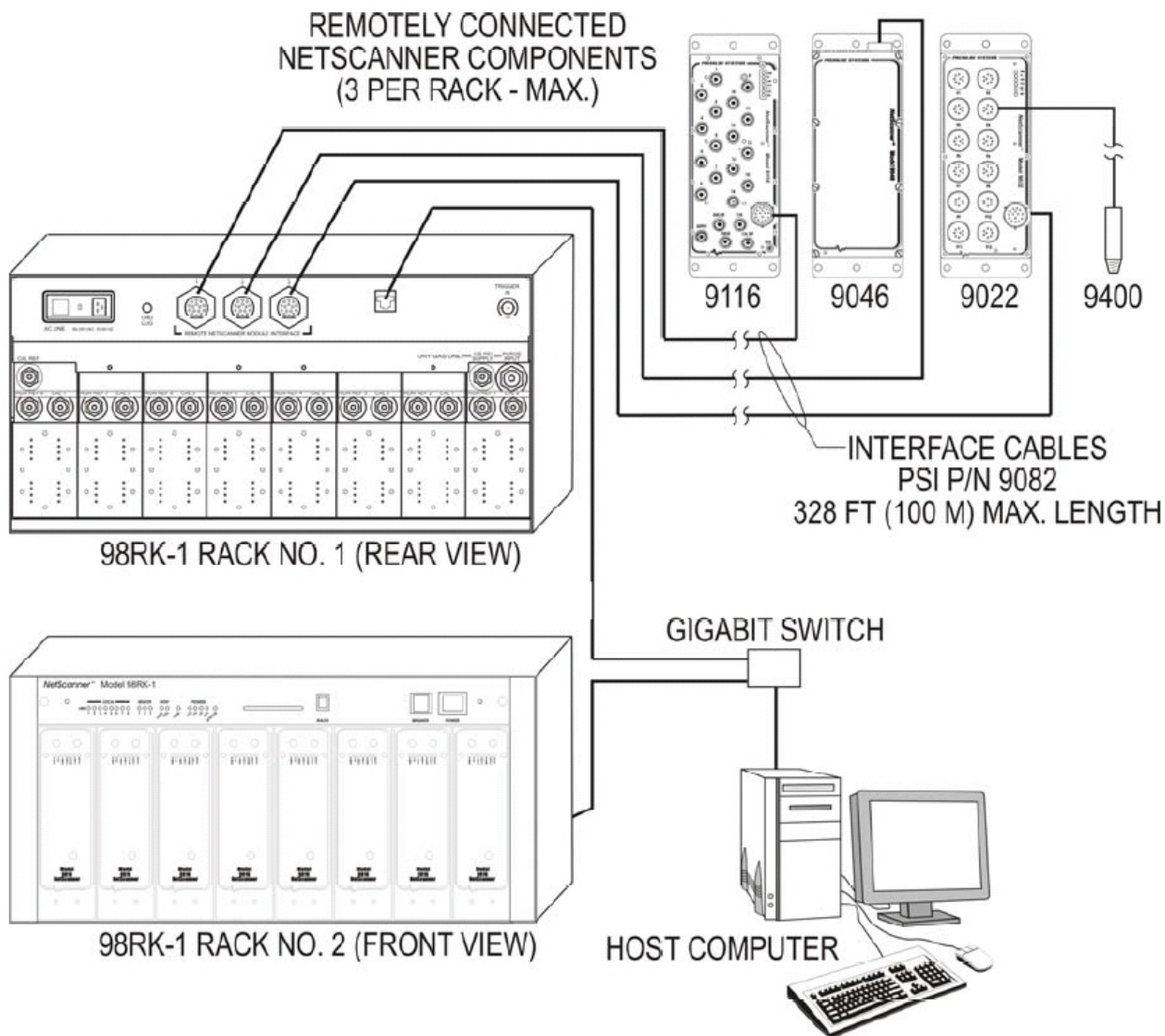

Ordering Information:

PN: **9816-AABBCC0000** 9816 Rackmount Intelligent Pressure Scanner

AA = Pressure Range (Consult Factory for multiple pressure range configurations and other ranges not listed)

01, 10"WC (2.5 kPa)	08, 30 psid (207 kPa)	99, Multirange
02, 20"WC (5.0 kPa)	09, 45 psid (310 kPa)	
03, 1 psid (7 kPa)	10, 100 psid (689 kPa)	
04, 2.5 psid (17 kPa)	11, 250 psid (1722 kPa)	
05, 5 psid (34 kPa)	12, 500 psid (3445 kPa)	
06, 10 psid (69 kPa)	32, 750 psid (5168 kPa)	
07, 15 psid (103 kPa)	39, 850 psid (5860 kPa)	

BB = Pneumatic Connection

- 01, 0.063", Front Access QDC
- 02, Rear Access QDC
- 03, 1/8" Compression Fitting, Front Access
- 05, 4mm Compression Fitting, Front Access

CC = Manifold Options

- 06, Common Differential
- 07, True Differential, Front Access only
- BB = 01 or 05

PN: **98RK-1** Scanner Interface Rack, Universal VAC Input

Example: 9816-0702060000 9816 Rackmount Intelligent Pressure Scanner, 15 psid, Rear Access, Common Differential

98RK-1 98RK-1 Scanner Interface Rack, Universal VAC Input