

Digitally Compensated All-Media Pressure Transducer

FEATURES

- Embedded EEPROM-based Calibration Data
- Digital Sensor Compensation
 - Up to $\pm 0.05\%$ FS Static Accuracy
 - Up to $\pm 0.005\%/^{\circ}\text{C}$ Thermal Stability
- Pressure ranges: 0-5 psi (34 kPa) to 0-10000 psi (69 Mpa)
- Welded 316 SS Construction

APPLICATIONS

- Turbomachinery Test Stands
- Process Control
- Environmental Monitoring
- Hydraulic/Pneumatic Systems



Series 9400 are highly accurate, digitally compensated pressure transducers designed specifically for use with PSI's 9022 All-Media Intelligent Pressure Scanners in applications requiring compatibility with liquid and high-pressure media. The 9400 utilizes a highly accurate pressure sensor assembly specifically designed for hostile fluids and gases. The assembly is integrated with supporting electronics in a durable waterproof housing constructed of 316 SS. Standard pressure ranges are available from 0-5 to 0-10,000 psi in gage, absolute and differential reference pressure formats.

Series 9400 transducers achieve high accuracy and thermal stability through the use of digital compensation technology to correct zero, span, and linearity errors over the operating pressure and temperature range. Each digitally compensated transducer contains an integral serial EEPROM storing factory generated calibration data. This data is uploaded into the Model 9022 Intelligent Pressure Scanners upon power-up and used to compensate for the inherent transducer errors during use. Static accuracy of up to $\pm 0.05\%$ FS with thermal stability up to $\pm 0.005\%/^{\circ}\text{C}$ are achieved using this technique. The Model 9022 scanners support output pressure measurements from the 9400 transducers in engineering units over an Ethernet interface using TCP or UDP protocols.

The Series 9400 All-Media Pressure Transducer is one component of the NetScanner™ System. Multiple NetScanner components measuring a variety of parameters and sharing the same command set can be networked to form a distributed intelligent data acquisition system.

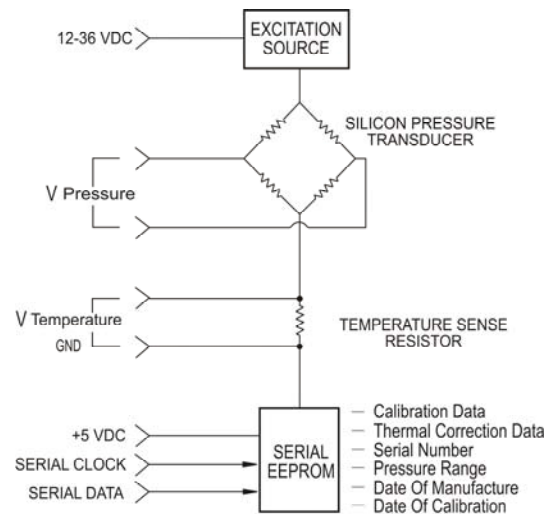

Electrical Block Diagram

After 1 hour warmup @ 25°C unless otherwise stated, FS = Full Scale

Parameter	9400	9401	9402	Units	Comments
PNEUMATICS					
Pressure Reference	Gage ¹	Absolute	Differential		
Pressure Ranges	5 (34) 10 (69) 15 (103) 50 (345) 100 (689) 250 (1724) 500 (3447) 750 (5171) 1000 (6895) 1500 (10342) 3000 (20684) 5000 (34474) 10000 (68947)	15 (103) 30 (207) 50 (345) 100 (689) 250 (1724) 500 (3447) 750 (5171) 1000 (6895) 1500 (10342) 3000 (20684) 5000 (34474) 10000 (68947)	5 (34) 10 (69) 15 (103) 50 (345) 100 (689) 250 (1724)	psi (kPa)	contact factory for other ranges
Proof Pressure ²		3.0 1.5		x FS	range <= 100 psi (689 kPa) range > 100 psi (689 kPa)
Burst Pressure		5x 3x 2x		x FS	range = 5-500 psi range > 500-3000 psi range > 3000 psi
STATIC PERFORMANCE					
Static Accuracy ³		±0.05 ±0.25 ±0.50	±0.5 N/A N/A	% FS % FS % FS	range < 750 psi range > 750 psi to <=3000 psi range > 3000 psi
Anti-Aliasing Filter		±0.005 ±0.05		% FS/°C % FS/°C	digital compensation ⁶ analog compensation ⁷
Thermal Hysteresis		±0.2		% FS	after cycling over full temp range
Max Line Pressure	N/A		1000 (6885)	psi (kPa)	
Line Pressure Effect ⁵	N/A		±0.01	% FS/psi	
ENVIRONMENTAL					
Wetted Materials	316 SS & Viton				
Compensated Temp Range	0 to 50 -30 to 40			°C	standard optional
Operating Temp Range	-30 to 100			°C	
ELECTRICAL					
Excitation	12-36			VDC	
Power Supply Rejection	±.001			%/VDC	
Output V_o V_t	0-4.9 3.0 – 4.0			VDC VDC	

Notes:

- 1 Pressure ranges > 750 psi are "sealed" gage rather than "vented" gage.
- 2 Maximum pressure which can be applied without causing calibration shift.
- 3 Static accuracy includes the combined errors due to nonlinearity, hysteresis and nonrepeatability following a zero calibration of the sensor.
- 4 Includes effects of zero and span relative to 25°C.
- 5 Primarily zero offset.
- 6 For digital compensation type transducers, the on-board EEPROM contains full operating range temperature and nonlinearity correction coefficients.
- 7 For analog compensation type transducers, the on-board EEPROM contains room temperature (approx. 25°C) nonlinearity correction coefficients.

Specifications subject to change without notice.

After 1 hour warmup @ 25°C with atmospheric reference pressure unless otherwise stated / FS = Full Scale

Parameter	9400	9401	9402	Units	Comments
ELECTRICAL (CONT'D)					
Output Impedance					
Vo		1000		Ohm	max
Vt		1000		Ohm	max
Insulation Resistance		50		M Ohm	@ 50 VDC
PHYSICAL/ENVIRONMENTAL					
Acceleration		±0.02 ±0.01		% FS/g % FS/g	range ≤ 15 psi (103 kPa) range ≥ 30 psi (207 kPa)
Vibration		±0.05		% FS/g	30 g peak 10 Hz – 2 kHz
Weight		6 (170)	17 (480)	oz (gm)	
Pressure Connection		1/4" NPT, Male AN4, Male G1/4, Male M14, Male	7/16-20, Female SAE o-ring Boss		
Electrical Connection		PTIH-12-8P Bendix PVC Jacketed Cable			
Standard					
Optional					

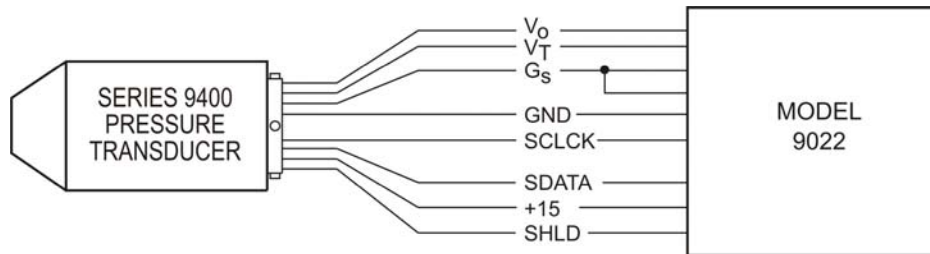

INTERFACE CONNECTION TO MODEL 9022

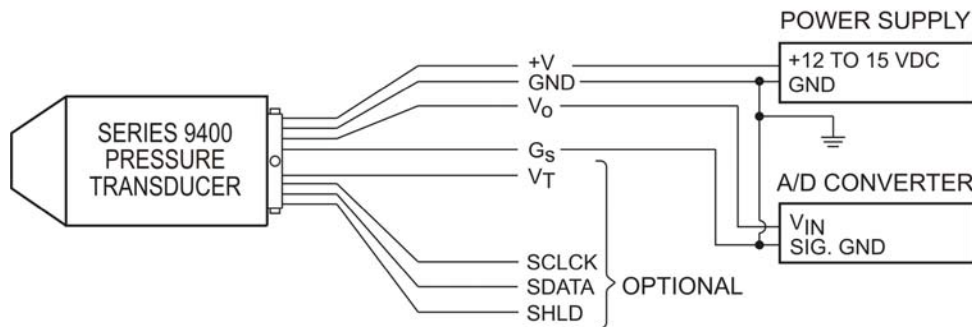

INTERFACE TO CUSTOM DATA ACQUISITION SYSTEM

Ordering Information:

PN: **9400-AAAABBC00EFF**
 PN: **9401-AAAABBC00EFF**

9400 All-Media Gage Pressure Transducer
 9401 All-Media Absolute Pressure Transducer

AAAA = Pressure Range

0005, 0-5 psi (34 kPa)
 0010, 0-10 psi (69 kPa)
 0015, 0-15 psi (103 kPa)
 0030, 0-30 psi (207 kPa)
 0050, 0-50 psi (345 kPa)
 0075, 0-75 psi (517 kPa)

0100, 0-100 psi (689 kPa)
 0150, 0-150 psi (1034 kPa)
 0250, 0-250 psi (1724 kPa)
 0500, 0-500 psi (3447 kPa)
 0750, 0-750 psi (5171 kPa)
 1000, 0-1000 psi (6895 kPa)

1500, 0-1500 psi (10342 kPa)
 2000, 0-2000 psi (13789 kPa)
 3000, 0-3000 psi (20684 kPa)
 5000, 0-5000 psi (34474 kPa)
 9999, 0-10000 psi (68947 kPa)

BB = Pressure Fitting

01, 1/4" NPT, Male
 02, AN4, Male
 03, BSPP, Male
 05, M14, Male

C = Electrical Connection

2, Bendix PTIH-12-8P Connector
 4, PVC Cable (for 9021)
 6, PVC Cable (for 9022)

E = Compensated Temp Range

0, Digital only (0 to 50°C)
 1, Analog only (0 to 50 °C)
 8, Analog only (-30 to 40°C)
 9, Digital only (-30 to 40°C)

FF = Attached cable length in feet, 2 ft min – 50 ft max (C = 4 or 6 only; if C=2, FF=00)

PN: **9402-AAAA04C00E**

9402 All-Media Differential Pressure Transducer

AAAA = Pressure Range

0005, 0-5 psi (34 kPa)
 0010, 0-10 psi (69 kPa)
 0015, 0-15 psi (103 kPa)

0050, 0-50 psi (345 kPa)
 0100, 0-100 psi (689 kPa)
 0250, 0-250 psi (1724 kPa)

C = Electrical Connection

2, PTIH-12-8P Bendix Connector
 4, PVC Cable (for 9021)
 6, PVC Cable (for 9022)

E = Compensated Temp Range

0, Digital only (0 to 50°C)
 1, Analog only (0 to 50 °C)
 8, Analog only (-30 to 40°C)
 9, Digital only (-30 to 40°C)

Example: **9400-001001200000**

9400 All-Media Pressure Transducer, 10 psig, 1/4" NPT, Bendix Connector, 0 to +50°C Digital

