

Barometer Pressure Standard Pressure Controller



NetScanner™ System

903x

FEATURES

- Up to $\pm 0.01\%$ FS Measurement and Control Accuracy
- $\pm 0.001\%/^{\circ}\text{C}$ Thermal Stability
- 10 BaseT Ethernet, TCP and UDP Protocol
- Pressure Ranges from ± 1 psid to 750 psia (± 7 kPa to 5171 kPa)

APPLICATIONS

- Barometric Measurement
- Pressure Scanner Verification Testing
- Pressure Scanner Span Calibration



Models 9034 and 9038 are compact pressure calibrators with set-point control accuracy of up to $\pm 0.01\%$ FS that are also capable of extraneous pressure measurement. The calibrators provide a pre-engineered solution for applying known stable pressures to electronic pressure scanners, or any pressure measurement device, for periodic calibration or verification.

Model 9032 and 9033 are precision pressure standards capable of measuring dry non-corrosive gases to an accuracy of $\pm 0.01\%$ FS. The Model 9032 Barometer offers an excellent solution for precision measurement of atmospheric pressures to complement differential electronic pressure scanners used in the acquisition of multiple pressures.

Available in absolute and differential versions, both products also provide digital I/O for electronic control of remotely located valves for use in routing measurement and control pressures as desired.

The units communicate with the host computer via a 10 Base-T Ethernet interface supporting both TCP and UDP protocols. Pressure data is output in user-selectable engineering units. An internal 32-bit microprocessor in each unit corrects for zero, span and non-linearity errors of the internal precision pressure standard. It also performs digital temperature compensation of the standard to reduce thermal errors to less than $\pm 0.001\%$ FS/ $^{\circ}\text{C}$.

The pressure standards and pressure controllers are components of the NetScanner™ System. Multiple NetScanner components measuring a variety of pressures and sharing the same command set can be networked to form a distributed intelligent data acquisition system.

34 Research Drive
Hampton, VA 23666
USA

www.PressureSystems.com

ISO-9001:2000 Certified

Phone: 757-865-1243
Toll Free: 800-328-3665
Fax: 757-865-8744
E-mail: sales@PressureSystems.com

© Copyright Pressure Systems, Inc., 2009

Specifications subject to change without notice.

After 1 hour warmup @ 25°C with atmospheric reference pressure unless otherwise stated / FS = Full Scale

Parameter	9032	9034	9033	9038	Units	Comments	
PNEUMATICS							
Reference Pressure Format	Absolute		Differential				
Pressure Range	11-16 (76-110) 15 (103) 23 (159) 30 (207) 45 (310) 65 (448) 100 (689) 200 (1379) 300 (2068) 500 (3447) 750 (5171)		±1 (7) ±5 (21)		psi (kPa)		
Media	Dry, non-corrosive gas						
Output Range ¹	N/A	5 to 100	N/A	-100 to 100	% FS	9038, see reference pressure	
Source Gas ²	Min	N/A	FS + 10 (69) 1.1	N/A	FS + 10 (69) N/A	psi (kPa) x FS	range ≤ 100 psi (689 kPa) range > 100 psi (689 kPa)
		Max	N/A	250 (1724) 1.5	N/A	250 (1724) N/A	psi (kPa) x FS
Vacuum ³	N/A		2 (60)	N/A	2 (60)	scfm (lpm)	
Output Flow Capacity	N/A	0.1 (3)	N/A	0.1 (3)	scfm (lpm)	min	
Overpressure ⁴ (input/output/ref ports)	1.3				x FS	max	
STATIC PERFORMANCE							
Measurement Resolution	±0.0005		±0.003		% FS		
Relative Accuracy ⁵	±0.01		±0.025		% FS		
Long Term Stability	±0.01		±0.05 ⁶		% FS/6 mos		
Thermal Stability ⁷	±0.001				% FS/°C	from 25°C	
Measurement Rate ⁸	10				readings/sec		
Controller Setpoint Resolution	N/A	0.003	N/A	0.003	% FS		

Specifications subject to change without notice.

After 1 hour warmup @ 25°C with atmospheric reference pressure unless otherwise stated / FS = Full Scale

Parameter	9032	9034	9033	9038	Units	Comments
ELECTRICAL						
Input Voltage	18 - 36				VDC	unregulated
Input Current	250 850				mA	@ 24 VDC, quiescent @ 24 VDC, active
Hardware Trigger Threshold	2.5				VDC	TTL compatible differential input, ±5 VDC common mode voltage
Digital Input/Output						
Output Voltage ⁹	18-36				VDC	max
Sink Current per Output	0.5				A	max
Max Source Current ¹⁰	1.0				A	max @ +24 VDC
COMMUNICATION						
Communication	10Base-T Ethernet				% FS	
Protocol	TCP and UDP				% FS	static or dynamic IP assignment
ENVIRONMENTAL/PHYSICAL						
Compensated Temp Range	0 to 50				°C	Contact factory for extended temperature range
	15 to 45				°C	range ≤ 5 psid
Operating Temp Range	-10 to 60				°C	Up to 95% non-condensing humidity
	0 to 50				°C	range ≤ 5 psid
Storage Temp	-20 to 80				°C	
	0 to 70				°C	range ≤ 5 psid
Size	9.5 x 3.5 x 3.875 (24.1 x 8.9 x 9.5)				inches (cm)	L x W x H, range < 750 psi
	9.5 x 6.375 x 3.85 (24.1 x 16.2 x 9.8)					L x W x H, range ≥ 750 psi range ≤ 5 psid
Weight	4.0 (1.8)	5.2 (2.3)	4.0 (1.8)	5.2 (2.3)	lb (kg)	range < 750 psi (5171 kPa) range ≥ 750 psi (5171 kPa) range ≤ 5 psid (21 kPa)
	5.8 (2.3)	7.0 (3.2)	N/A	N/A	lb (kg)	
	N/A	N/A	7.4 (3.6)	8.6 (3.9)	lb (kg)	

Notes:

- 1 Control of subatmospheric pressures requires vacuum pump.
- 2 Gas should be pre-filtered to 10 microns, free of oil and have dew point of -25°C.
- 3 Required for control of subatmospheric pressure, recommended for control near zero psig (kPa).
- 4 For absolute reference units (9032 & 9034), overpressure is defined as the maximum absolute pressure which may be applied to the unit without damage. For differential units (9033 & 9038), overpressure is defined as the maximum pressure differential between the pressure standard input and reference.
- 5 Relative accuracy includes the combined errors due to non linearity, hysteresis and non-repeatability.
- 6 After internal rezero
- 7 Includes effects of zero and span.
- 8 Measurement rate to host computer depends on host computer software throughput rate. Consult users manual for more information.
- 9 Output voltage directly equivalent to 903x input voltage supply.
- 10 Maximum sink/source current for all external control outputs.

9032

The absolute reference 9032 is designed to measure a single absolute pressure. The quartz standard is connected directly to the input port. The relief valve is set to vent at 110% of the instrument's full scale pressure. The 9032 is most commonly used as a barometer, where the range is specifically calibrated for use at 11-16 psia (770-1100 mbar).

9033

The differential reference 9033 is designed to measure a single differential pressure. Normally the high side is connected to the input port while the low side would be connected to the reference input. The instrument is designed to measure differential pressure at a maximum common mode (line) pressure of 200 psia (1380 kPa). The bi-directional relief valves vent if either input exceeds the other by 110% of the instrument's full scale pressure. The rezero solenoid allows the user to minimize zero error due to line pressure, temperature and drift with time on the pressure standard.

9034

The absolute reference 9034 is designed to control pressure between 5%-100% of the instrument's full scale pressure range. A digitally controlled pneumatic servo valve modulates the mix of supply/vent pressure to its output allowing pressures to be controlled from near vacuum to the full scale of the instrument. A quartz pressure standard measures the servo valve output. The microprocessor adjusts this valve to set the requested pressure. The instrument may also be used in a measurement mode by applying the pressure to be measured at the output port. The pressure relief valve is designed to vent at 110% of the instrument's full scale pressure. The 750 psia unit does not contain a pressure relief valve.

9038

The differential reference 9038 is designed to control pressures between vacuum and +100 % of the instrument's full scale pressure range. The instrument will control pressures at elevated reference (line) pressures. As an example, if the applied reference pressure was 10 psi (69 kPa) and the requested control pressure was 5.0 psi (35 kPa), the instrument would output 15 psi (105 kPa) on the output port. Standard units are manufactured for atmospheric reference. Elevated reference pressure requires factory modifications. The pressure standard is measured under microprocessor control to maintain the desired control pressure. The rezero solenoid allows the user to execute pneumatic rezero of the pressure standard on demand. The instrument may also be used in a measurement mode by applying the pressure to be measured to the output port. The instrument is protected by bi-directional relief valves designed to vent whenever either the output or reference port exceeds the other by 110% of the full scale pressure.

9032 PRESSURE STANDARD

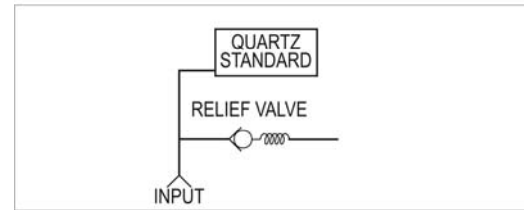

9033 PRESSURE STANDARD

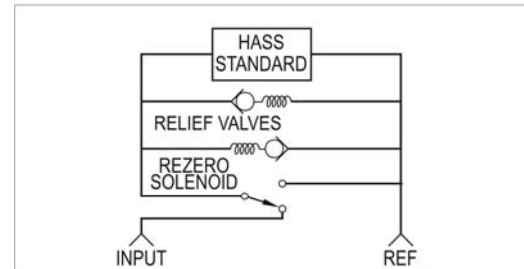

9034 PRESSURE CONTROLLER

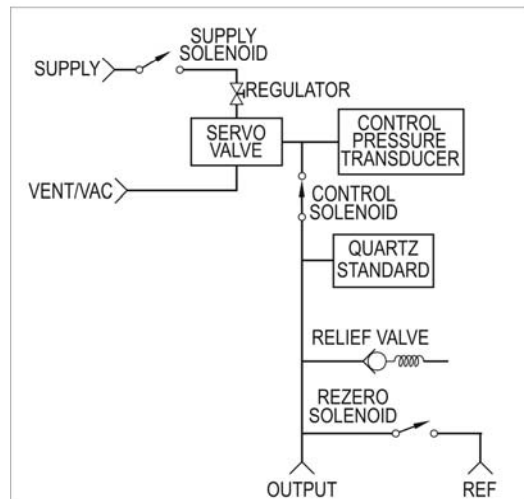

9038 PRESSURE CONTROLLER

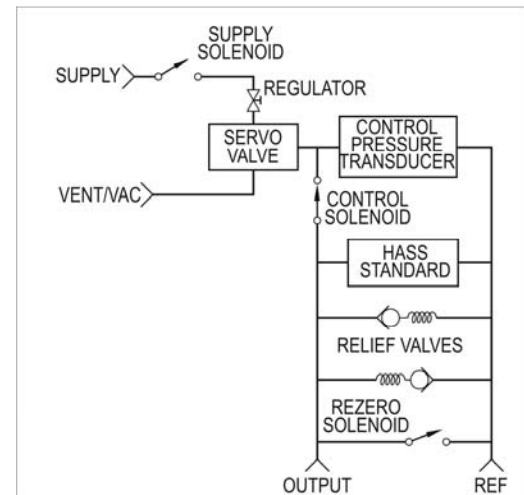

Digital I/O

Digital I/O is available on the front panel for user applications. A software command allows each of the outputs, K1 - K4, to be independently set or reset. The open-collector output drivers can operate external solenoids or external pull-up resistors can be connected to provide logic outputs. Up to 1A of 18-36 VDC power is available for external use. External solenoids requiring less than 0.5A may be directly connected to the I/O connector. The output current for each driver should not exceed 0.5A and the total current, for all four outputs, should not exceed 1A.

A software command is used to read the four digital inputs, D1 - D4. These inputs can be used to sense TTL signals or external pull-up resistors may be added to sense contact closures. Up to 50 V may be applied without damage.

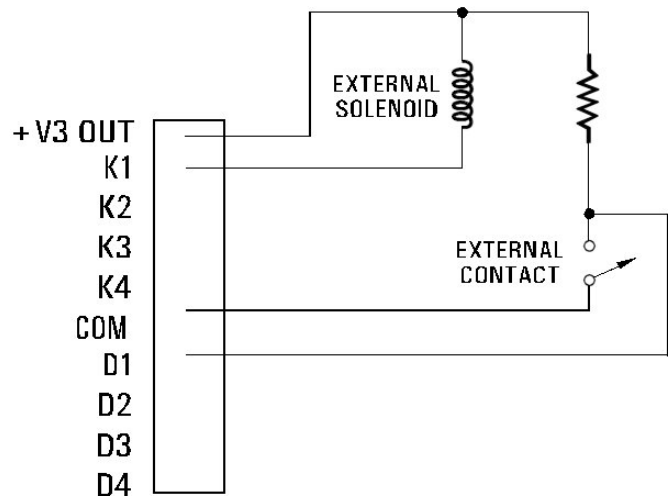
**External Digital I/O****Networking and Software**

The 9032/9033/9034/9038 are part of a networked solution for pressure measurement and pressure control. These modules are networked via Ethernet 10 Base-T using commonly available networking hardware. Interface can be direct to a host computer using a standard Ethernet card, with PSI networking hardware or via an appropriate local area network (LAN).

The internal microprocessor performs the more complex tasks like engineering unit calculation and pressure control. A standard command set allows the user to send simple commands to read pressures and set pressures.

READ PRESSURE

The 9032 and 9034 can be used to accurately measure an absolute pressure. Barometric pressure is the most common measurement pressure. The 9033 and 9038 can be used to accurately measure a differential pressure applied to the input ports of the unit. One simple command is sent to request current pressure readings. Data may be returned in several user selected output formats.

REZERO PRESSURE STANDARD

From time to time, the user may rezero the differential sensor of the 9033/9038 by commanding the unit to perform an on-line pneumatic rezero. This causes the instrument to shunt the sensor input and the reference sides together. The transducer is then read and the offset is used to remove any thermal or long term drift which has occurred since the calibration. The rezero term may be stored in instrument nonvolatile memory for later use.

SET PRESSURE

The 9034 and 9038 may be used to accurately control a pressure by one or more commands. Single point pressures may be generated by a single command. A sequence of pressures may be generated which the user has stored within the instrument. The 9034/9038 can automatically set a predefined sequence of pressures, holding each set point for a user defined period of time. The instrument may also advance through the sequence of pressures in response to host computer commands.

Front Panel Layout

The instrument's front panel contains all pneumatic and electrical connections necessary to operate the device. The unit is supplied with standard English or optional metric pneumatic fittings. Mating electrical connector or combined networking/power/trigger cable are specified separately. Maximum cable length is 328 ft (100 m).

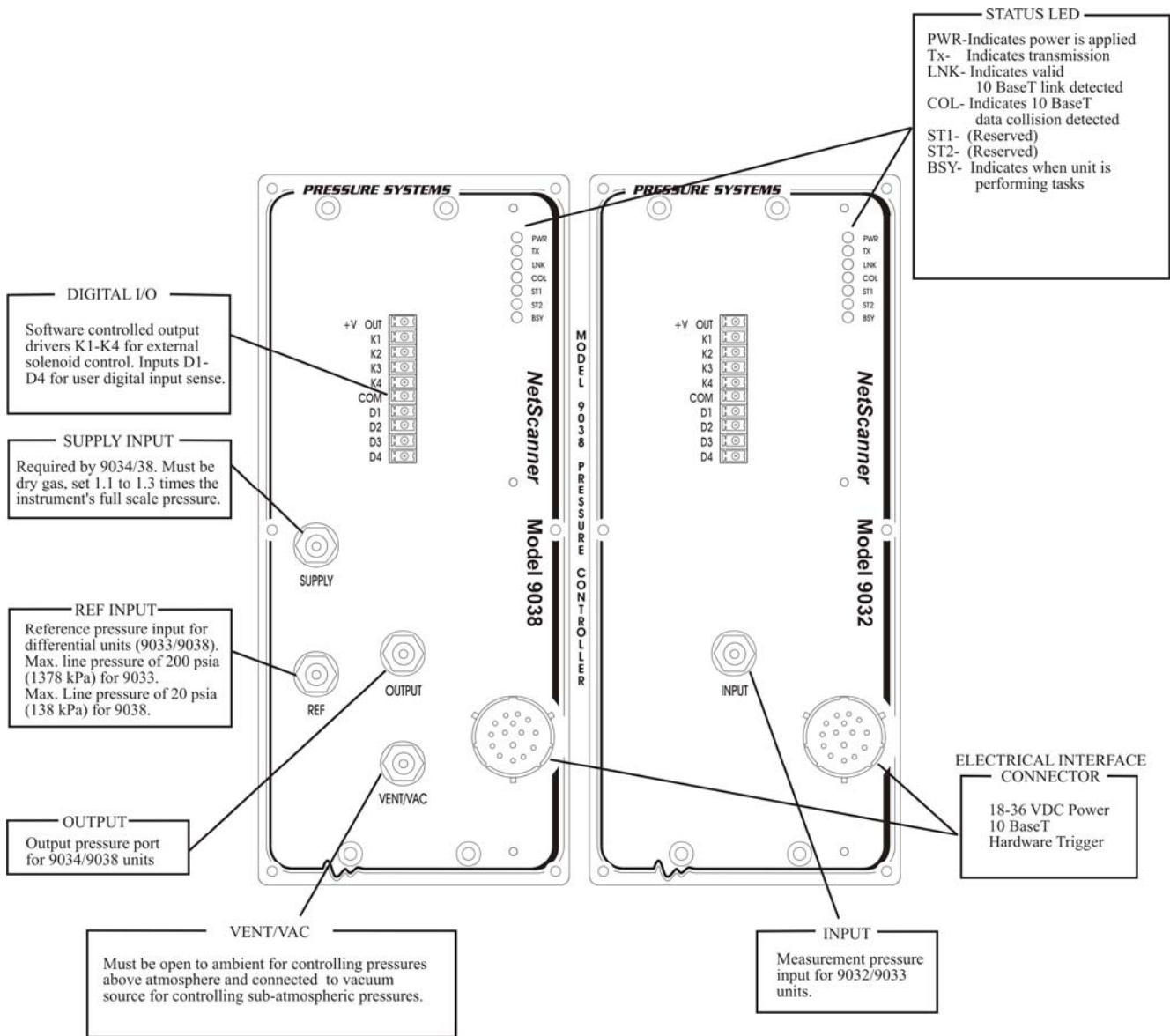

This example depicts the electrical/pneumatic connection and required cables and support equipment necessary to interface a 9038 to a host computer. Shop air may be used for the supply if it is free of moisture, oil and contaminants.

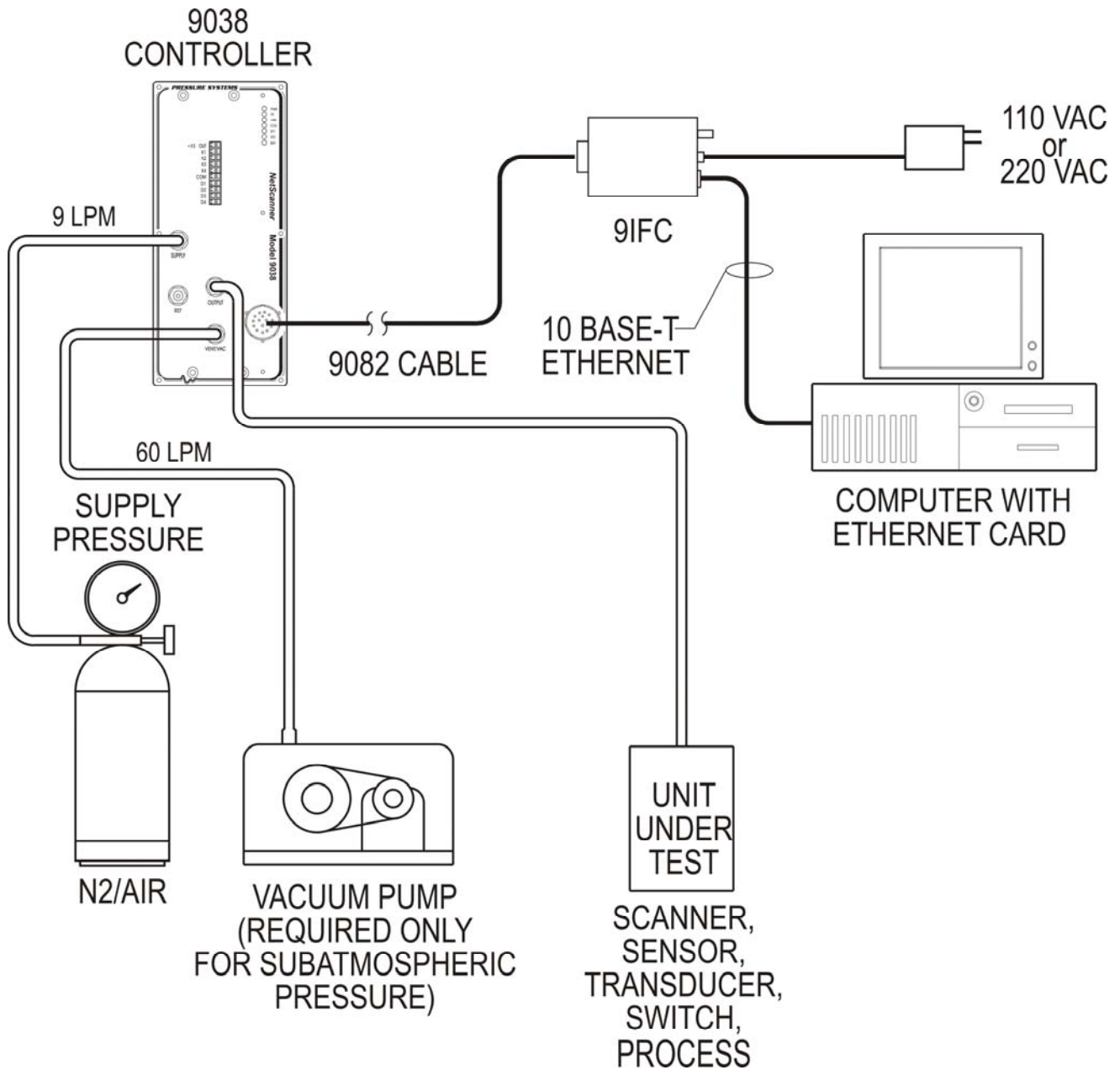

Ordering Information:

PN: **9032-9900CC0300** Barometer, 11-16 psia, (76 - 110 kPa)

CC = Pneumatic Connection

- | | |
|-------------------------------|------------------------------|
| 01, 1/4" Compression Fittings | 03, 4mm Compression Fittings |
| 02, 1/8" Compression Fittings | 04, 6mm Compression Fittings |

PN: **9032-AA00CC0300** Pressure Standard, Absolute
9034-AA00CC0300 Pressure Controller, Absolute

AA = Pressure Range

- | | | |
|-------------------------|-------------------------|-------------------------|
| 01, 15 psia (103 kPa) | 03, 30 psia (207 kPa) | 65, 65 psia (448 kPa) |
| 10, 100 psia (689 kPa) | 30, 300 psia (2068 kPa) | 75, 750 psia (5171 kPa) |
| 23, 23 psia (159 kPa) | 45, 45 psia (310 kPa) | |
| 20, 200 psia (1379 kPa) | 50, 500 psia (3447 kPa) | |

CC = Pneumatic Connection

- 01, 1/4" Compression Fittings
- 02, 1/8" Compression Fittings
- 03, 4mm Compression Fittings
- 04, 6mm Compression Fittings

D = Case Size

- 0, Single width, standard
- 1, Double width, required for 750 psia

PN: **9033-AA00CCD300** Pressure Standard, Differential, Ethernet
9038-AA00CCD300 Pressure Controller, Differential, Ethernet

AA = Pressure Range

- 01, ±1 psid (7 kPa)
- 02, ±2 psid (14 kPa)
- 05, ±5 psid (21 kPa)

CC = Pneumatic Connection

- 01, 1/4" Compression Fittings
- 02, 1/8" Compression Fittings
- 03, 4mm Compression Fittings
- 04, 6mm Compression Fittings

D = Case Size

- 0, Single width, standard
- 1, Double width, required for 1 and 5 psid

